

# TECHNICAL DATASHEET



## EF REDUCED TEE 90°

04 Update - 04/2024

### TECHNICAL DATA

Article No	001 117 2042 0113
d1 (mm)	110
d2 (mm)	63
D (mm)	138
Z (mm)	260
L (mm)	149
le1 (mm)	72
le2 (mm)	67
m (mm)	35
Weight (Kg)	1,530
Box Quantity (pcs)	6
Box Dimension (cm)	55x30x37,5

### INJECTION MOULDED

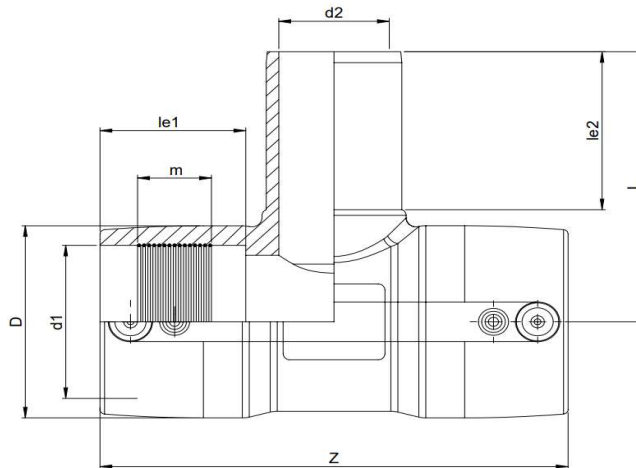

### IDENTIFICATION OF PRODUCT

D(mm)	110-63
SDR	11
RAW MATERIAL	PE 100
PRESSURE CLASS	16 Bar Water 10 Bar Gas
TRADEMARK	NTG
EXECUTION	Injection Moulded
STANDARD	EN 12201-3 EN 1555-3 AS / NZS 4129
SPECIFICATION	Suitable for SDR9...17 pipe 4 mm pin connectors

### EF SPECIFICATION

WELDING VOLTAGE	40V
RESISTANCE	0,95 Ω
WELDING TIME	150 Sec.
COOLING TIME	15 Min.
WINDING TYPE	Monofilar
WELDING BARCODE	



971420321103400956150111

Tolerance on diameters and thickness according to the standards. The other dimensions are specialized. Tolerance  $\pm 5\%$ . NTG PLASTIK reserves all the right to change any information without giving prior notice. The production, distribution and utilization of this document without explicit authorization is prohibited.